



# Organization of American States

**BID No. 05/17**

**REQUEST FOR PROPOSALS**

**FOR**

**CAPITAL LEASE FINANCING FOR INFORMATION TECHNOLOGY EQUIPMENT, SOFTWARE AND  
ASSOCIATED PROFESSIONAL SERVICES FOR THE GENERAL SECRETARIAT OF THE  
ORGANIZATION OF AMERICAN STATES**

**DEPARTMENT OF INFORMATION AND TECHNOLOGY SERVICES (DOITS)**

**SECRETARIAT FOR ADMINISTRATION AND FINANCE (SAF)**

**GENERAL SECRETARIAT OF THE ORGANIZATION OF AMERICAN STATES (GS/OAS)  
Department of Procurement Services**

**June, 12th 2017**

## TABLE OF CONTENTS

1. General Information
2. Objective
3. Terms of Reference
4. Governing Law
5. RFP Schedule
6. Bidders' Inquiries
7. Proposal Submission Requirements
8. Proposal Evaluation
9. Contract Award
10. Lease Agreement
11. General Provisions

### Appendixes

- |            |                                  |
|------------|----------------------------------|
| Appendix 1 | Terms of Reference               |
| Appendix 2 | Contractual Terms and Conditions |
| Appendix 3 | Formats                          |

**BID No. 05/17**

**REQUEST FOR PROPOSALS**

**FOR**

**CAPITAL LEASE FINANCING FOR INFORMATION TECHNOLOGY EQUIPMENT, SOFTWARE AND ASSOCIATED PROFESSIONAL SERVICES FOR THE GENERAL SECRETARIAT OF THE ORGANIZATION OF AMERICAN STATES**

**1. GENERAL INFORMATION**

The Organization of American States (OAS) is a public international organization, with headquarters at 1889 F. St. N.W., Washington, D.C. 20006. The OAS brings together the nations of the Western hemisphere to promote democracy, strengthen human rights, foster peace, security and cooperation and advance common interests. For more information about the OAS, please refer to the OAS's web site at [www.oas.org](http://www.oas.org).

The General Secretariat of the OAS (GS/OAS) is the central and permanent organ of the OAS in accordance with Article 107 of the Charter.

The Department of Information and Technology Services of the GS/OAS (DOITS) is responsible for the IT asset management of the GS/OAS and for establishing and maintaining standards governing equipment and software that may be acquired and installed at the GS/OAS.

**2. OBJECTIVE**

The purpose of this Request for Proposals (RFP) is to solicit proposals from qualified firms to enter into a technology capital lease contract (hereinafter, Contract, Lease, Lease Agreement or Project) with the GS/OAS for the financing of the technological upgrade of existing Information Technology equipment, software and associated professional services, as described in Appendix 1 of this RFP, Terms of Reference.

The estimated Project amount is approximately \$3,000,000 for a five (5) year Lease including all taxes, if applicable, like property taxes, and the corresponding interests inherent to the lease. Authority for technology capital lease purchases is contained in the GS/OAS' approved budget. The GS/OAS has the right to adjust the amount to be financed and to utilize alternative financing mechanisms.

The Lease's term of financing will be five (5) years, with option to extend the Lease.

### 3. TERMS OF REFERENCE

The Terms of Reference (TORs) of the capital lease financing for IT equipment, software and associated professional services for the GS/OAS are outlined in Appendix 1 of this RFP, and, therefore, become part of it.

### 4. GOVERNING LAW

This selection process is regulated by:

- 4.1 This RFP.
- 4.2 The Procurement Contract Rules of the GS/OAS, approved by Executive Order No.00-1.
- 4.3 The Performance Contract Rules, approved by Executive Order No. 05-04, Corr. No. 1.
- 4.4 The Executive Orders, memoranda and other dispositions and official documents of the GS/OAS applicable to this process.

### 5. RFP SCHEDULE

The following schedule reflects the expected completion dates but may be modified by the GS/OAS at its sole discretion:

Issue Request for Proposals	06/12/2017
Bidder's inquiries due	06/20/2017
Response to Bidder's Inquiries Due	06/23/2017
Proposal Closing Date	06/27/2017
Interviews with Bidders (if required)	07/05/2017 - 07/07/2017
Contract Award	07/19/2017
Expected Lease Start Date	TBD with the Lessor

### 6. BIDDERS' INQUIRIES

- 6.1 Bidders may submit any inquiry or request for more information and clarification regarding technical specifications in this RFP no later than 06/20/2017.
- 6.2 The requests must be submitted in a written format to the attention of Mr. Alex P. Grammer, Director of the Department of Procurement Services (DP), by e-mail to: [oasbidssubmit@oas.org](mailto:oasbidssubmit@oas.org), with copy to [vcastro@oas.org](mailto:vcastro@oas.org).
- 6.3 The responses to these requests will be submitted in written format to all Bidders no later than 06/23/2017.

## 7. PROPOSAL SUBMISSION REQUIREMENTS

### 7.1 Terms and Conditions

- 7.1.1 By submitting a Proposal, the Bidder gives express warranty of its knowledge and acceptance of RFP and the rules and conditions that governs the bidding process. Likewise, the Bidder represents and warrants that it has studied and is thoroughly familiarized with the requirements and specifications of the Project in its entirety. This includes familiarity with the TORs and the Contract documents attached to the RFP, with all current equipment, labor, material market conditions, shipping and with applicable laws, such that the Bidder accepts responsibility for and is prepared to execute and shall completely fulfill all obligations under the Lease.
- 7.1.2 By submitting a Proposal, Bidder gives express warranty of the accuracy and reliability of all information it submits in this procurement process.
- 7.1.3 By submitting a Proposal, the Bidder gives express warranty of its knowledge that its Proposal does not create any right in or expectation to a contract with the GS/OAS.
- 7.1.4 The Bidder shall bear any and all costs or expenses associated with or incurred in the formulation or development of a Proposal in response to this RFP.

### 7.2 Submittal Format

- 7.2.1 Proposals shall be submitted in three (3) sealed envelopes. The first envelope will contain the Technical Proposal; the second envelope will contain the Price Proposal; and the third envelope will contain the legal documentation required in section 7.3.3.
- 7.2.2 The Proposals shall be submitted in hard copy: one (1) original and one (1) copy. The sealed envelope containing Bidder's Proposal shall be labeled as follows:

**GS/OAS BID No. 05/17 – CAPITAL LEASE FINANCING FOR INFORMATION  
TECHNOLOGY EQUIPMENT, SOFTWARE AND ASSOCIATED PROFESSIONAL  
SERVICES FOR THE GS/OAS**

\_\_\_\_\_ (*Bidder's Name*)

- 7.2.3 The Proposals shall be delivered to:

The General Secretariat of the Organization of American States  
Department of Procurement Services  
1889 F Street, N.W., 4<sup>th</sup> Floor  
Washington, DC 20006  
USA

7.2.4 Additionally, the Proposals shall be submitted by electronic mail to the attention of Mr. Alex P. Grahammer, Director of the Department of Procurement Services. Proposals sent by e-mail should be in PDF format, sent to [oasbidssubmit@oas.org](mailto:oasbidssubmit@oas.org) with copy to [ycaastro@oas.org](mailto:ycaastro@oas.org). The electronic proposal must not exceed 15 MB in total size due to OAS e-mail restrictions. Should the electronic bid package exceed 15MB in size, the bidder should use its corporate file share application to provide a download link to have access to the bid package. The electronic Proposal and the hardcopy Proposal must be identical. Failure to do so may result in disqualification of Bidder's Proposal.

7.2.5 The Proposals shall be signed by the Bidder's legal representative.

7.2.6 Any firm may bid independently or in joint venture confirming joint and several liability, either with domestic firms and/or with foreign firms. The GS/OAS does not accept conditions of bidding which require mandatory joint ventures or other forms of mandatory association between firms.

### **7.3 Required Documents and Formats in the Proposals**

#### **7.3.1 Content of the Technical Proposal:**

The Technical Proposal shall include the following information/documents:

##### ***Documents related to Bidder's Experience***

- a) A general description of the background and organization of the bidding firm.
- b) A detailed description of the Bidder's work experience similar or relevant to this Project. The description shall substantiate its qualifications and capabilities to satisfy the requirements of the RFP.
- c) A minimum of five (5) references from Bidder's clients to which similar or relevant services were provided during the last three (3) years. These references should include: the name of the client, contact person, telephone and fax numbers and e-mail address, and a description of the work performed and the duration of the Project. Please follow Format 2 of Appendix 3.

##### ***Documents related to the Project***

- d) A Statement of Work (SOW) which shall include a description of the basic infrastructure and associated professional services offered, implementation methodology, deliverables, and an estimated timeline for delivery of the requested services (milestones), in accordance with the TORs, Appendix 1 of this RFP.
- e) If the Bidder plans to perform the work with subcontractors and/or in joint venture with other firms, an explanation of the relationship between the firms and how potential inefficiencies in the organization, communications, and Project processes can be avoided. If the form of a joint venture is considered, the Technical Proposal should additionally address joint and

other liabilities for all partners.

***Documents related to Bidder's Personnel***

- f) The resume of the lead professional staff person who will be assigned to this project as "Project Manager", and two concise but descriptive summaries of this person's prior experience with similar projects. Professional skills and previous experience of the technical team to be assign to the Project is required.

***Documents related to the Master Lease Agreement and Other Lease Documents***

- g) Copies of all standard documentation required to execute financing. This includes but is not limited to the Master Lease Agreement, equipment schedules, escrow agreement, guarantees, upfront payment requirements, and any security deposit requirements.
- h) Also, each Bidder must indicate any specific covenants or security features that will be required to obtain a financing commitment.
- i) Bidders wishing to negotiate modification of the Contractual Terms and Conditions the GS/OAS stated in Appendix 2 of this RFP must attach a copy of the GS/OAS's RFP and show proposed changes (deleted sections with a strike over and added sections in boldface type). Bidder's failure to identify any such changes in its Proposal will preclude the Bidder from raising any such changes thereafter. If Proposals are subject to additional terms, that the GS/OAS decides are not in its best interest, the GS/OAS reserves the right to deem that Proposal as unresponsive.

***Bidder's Point of Contact***

- j) Information of Bidder's point(s) of contact. Provide the name, position, telephone number, email, and fax of the person or persons serving as coordinator or focal point of information of the Bidder concerning this bidding process.

**7.3.2 Content of the Price Proposal:**

The Bidders shall submit a Price Proposal expressed in US Dollars (US\$).

The Price Proposal should be calculated with yearly payments in arrears. The annual interest rate, any applicable taxes (like property taxes) the yearly payment amount, and the total payment amount should be included in the Price Proposal.

The Price Proposal should be presented identifying the following unit prices:

- a) The total cost of the basic infrastructure offered, as required in section 3 of the TORs. Such price must not exceed GS/OAS available budget (\$3,000,000) and shall include the total amount of interest throughout the 5 years period plus applicable taxes and must include the total cost of all professional services including a Project Manager needed in order to deploy and configure

each area of the basic infrastructure, as required in section 3 of the TORs, and

- b) The total cost of each optional infrastructure and service offered, as required in section 4 of the TORs. The cost of the optional infrastructure and services must be itemized and presented following the same categories and subcategories listed in section 4 of the TORs.

Because of the length of time between the Proposals are due and the GS/OAS expects to sign the Lease Agreement, the Price Proposals shall include a fixed price that is good for at least ninety (90) days from the proposal due date to and including the timeline lease closing date of October 19<sup>th</sup>, 2017.

A fixed price Lease will be signed with the prospective Lessor, therefore the unit prices mentioned in the Price Proposal shall include all anticipated expenses, including but not limited to, fee, taxes and other costs associated with the Project, in accordance with the TOR, Appendix 1 of this RFP.

### 7.3.3 Legal Documentation:

- a) A copy of the Bidder's certificate of incorporation issued by the competent authority of its country.
- b) A copy of the Bidder's bylaws.
- c) A copy of the Bidder's licenses and certifications in the corresponding jurisdiction (if required under the law of the duty station where the work is to be performed).
- d) A copy of the W-9 Form for US Companies and the Employer Identification Number for companies outside of the US.
- e) A copy of the Bidder's latest general balance sheet of 2015 or 2016; and copy of the Bidder's latest three (3) audited financial statements, for the years 2014, 2015 or 2016. These financial statements must be signed and/or appropriately certified by the Chief Financial Officer of the Bidder. In addition, the Bidder's DUNS number, only if applicable.
- f) A list of the directors, officers, and the names of any stockholder with more than 50% of the stock.
- g) A disclosure statement of conflict of interest. The statement should follow Format 1 of Appendix 3. In the event of the Bidder intends to subcontract or perform the Contract in joint venture, such statement shall be also disclosure by the subcontractors and by each member of the joint venture.

## 7.4 Limited Use of Data

If the Proposal includes data that the Bidder does not want to disclose to the public for any purpose or used by the GS/OAS except for evaluation purposes, the Bidder shall include in its Proposal a statement signed by its legal representative with the following legend:



## USE AND DISCLOSURE OF DATA

*This Proposal includes data that shall not be disclosed outside the GS/OAS and shall not be duplicated, used, or disclosed— in whole or in part—for any purpose other than to evaluate this Proposal. If, however, a contract is awarded to this Bidder as a result of—or in connection with—the submission of this data, the GS/OAS shall have the right to duplicate, use, or disclose the data to the extent provided in the resulting contract. This restriction does not limit the GS/OAS' right to use information contained in this data if it is obtained from another source without restriction. The data subject to this restriction are contained in sheets [insert numbers or other identification of sheets].*

### **7.5 Closing Date for Receipt of Proposals**

7.5.1 Both the hard copy and electronic Proposals must be received by the GS/OAS no later than close of business (COB) **June 27<sup>th</sup> 2017**.

7.5.2 Proposals submitted after the deadline will not be considered.

## **8. PROPOSAL EVALUATION**

### **8.1 Terms and Conditions**

This RFP does not in any manner whatsoever constitute a commitment or obligation on the part of GS/OAS to accept any Proposal, in whole or in part, received in response to this RFP, nor does it constitute any obligation by GS/OAS to acquire any goods or services.

The GS/OAS has the right to reject any and all Proposals, to disqualify any Proposals not following RFP communication procedures, and to disqualify any Proposals not responsive to the award criteria specified in section 8.3 below.

### **8.2 Requests for Clarification and Exchange with Bidders**

In order to enhance the GS/OAS' understanding of Proposals, allow reasonable interpretation of the Proposals, or facilitate the evaluation process, the GS/OAS reserves the right to request written or oral clarification of submitted information and to request additional information from Bidders.

For that purpose the GS/OAS, through DP, will submit, in writing, any inquiry or request (including interview requests) to the Bidders for explanation, substantiation or clarification of certain aspects of their Proposals. Such requests will be addressed to the point of contact indicated by the Bidders in their Proposal.

Likewise, during the evaluation process, the GS/OAS may offer the Bidders an

opportunity to eliminate minor irregularities, informalities, or apparent clerical mistakes in their Proposals. Requests for clarifications will not be used to cure Proposal deficiencies or material omissions that materially alter the technical or cost elements of the Proposal.

### **8.3 Award Criteria**

Proposals will be admitted for evaluation only if they comply with the mandatory minimums contained in the TORs. Once admitted, the GS/OAS will review, evaluate, and compare those Proposals according to, but not necessarily limited to, the following criteria:

#### **8.3.1 Technical Criteria:**

- a) Responsiveness: Whether the Bidder's Technical Proposal conforms in all material respects to the RFP.
- b) Relevant Experience / Past Performance: Bidder's relevant experience and past performance will be evaluated in respect to past or current efforts similar or relevant to this Project.
- c) Statement of Work (SOW): Assesses the completeness of the Proposal in order to determine timely performance and technical compliance. Assesses the work methodology, as well as the tools and procedures presented by the Bidder, to achieve the objectives of this Project.
- d) Experience and Qualification of the Project Manager: Assesses the qualifications and relevant experience of the Project Manager that the Bidder proposes to assign to this transaction.
- e) References Check: The GS/OAS will request performance information from Bidder's previous clients.
- f) Financial Capability: Assesses the financial condition of the Bidder to perform the Lease through the review of the Bidder's financial statements.
- g) Schedule Compliance. Analyses the ability of the Bidder to comply with the required performance schedule.

#### **8.3.2 Price Criteria**

- a) Price Proposal.

### **8.4 Discussions and Negotiations**

Before awarding the Contract, the GS/OAS may choose to have written or oral discussions and/or negotiations regarding the terms, conditions and deliverables of the Lease with the Bidders that, in the opinion of GS/OAS, are within the competitive range.

For that purpose the GS/OAS, through DP, will submit, in writing, any request (including interview requests) to the Bidders. Such requests will be addressed to the point of contact indicated by the Bidders in their Proposal.

During the negotiations, the GS/OAS may request the Bidders to revise or modify their Proposals. After the negotiations the GS/OAS may issue a request for Best and Final Offer (BAFO).

## **9. CONTRACT AWARD**

9.1 The trade-off analysis decisional rule will be applied for the evaluation of the Proposals. Under this rule, the GS/OAS will evaluate both price and non-price factors and will award the Lease to the Bidder proposing the combination of factors which offers best value to the GS/OAS. Therefore, the GS/OAS reserves the right to consider award to other than the lowest price bidder or the highest technically rated bidder.

9.2 The award will be notified to the winning Bidder. Such communication shall not be construed as a Contract with the GS/OAS. The award is contingent upon the winning Bidder's acceptance of the terms and conditions of the Lease Agreement

## **10. LEASE AGREEMENT**

10.1 The Lease Agreement will be drafted by the GS/OAS based on this RFP, the winning Proposal, and the results of the negotiations with the selected Bidder. Consequently, the Lease Agreement shall come into effect when signed by both GS/OAS and the duly authorized representative of the winning Bidder.

10.2 Appendix 2 of this RFP contains the Contractual Terms and Conditions that will be part of the Lease Agreement. No changes to the Contractual Terms and Conditions shall be accepted after the contract award. Once the Contract is awarded, the Lessor shall be bound by such Contractual Terms and Conditions either as stated herein in the RFP or as mutually modified by the Parties.

10.3 The GS/OAS selection of any Bidder who proposes changes to the Contractual Terms and Conditions shall not be deemed as acceptance of the Bidder's proposed changes.

10.4 At all times, the GS/OAS reserves the right to use its own lease documents and to negotiate changes in the proposed agreements. The GS/OAS reserves the right to accept or reject any changes in language and reserves the right to make final conforming changes to the documents.

## **11. GENERAL PROVISIONS**

### **11.1 Privileges and Immunities**

11.1.1 Nothing in this RFP shall constitute an express or implied agreement or waiver by the GS/OAS, the OAS, or their personnel of their privileges and immunities under the OAS Charter, the laws of the United States of America, or international law.

11.1.2 The Bidders are not entitled to any of the exemptions, privileges or immunities, which the GS/OAS may enjoy arising from GS/OAS status as a public international organization.

## APPENDIX 1

### TERMS OF REFERENCE

#### CAPITAL LEASE FINANCING FOR INFORMATION TECHNOLOGY EQUIPMENT, SOFTWARE AND ASSOCIATED PROFESSIONAL SERVICES

##### 1. Introduction

GS/OAS headquarters main campus consists of three buildings as follow:

1. General Services Building (GSB) located at 1889 F St. NW Washington, DC 20006
2. Administrative Building (ADM) located at 1809 Constitution Ave. NW. between 18th and 19th Streets Washington, DC 20006
3. Main Building (MNB) located at 200 17th Street NW Washington, DC 20006

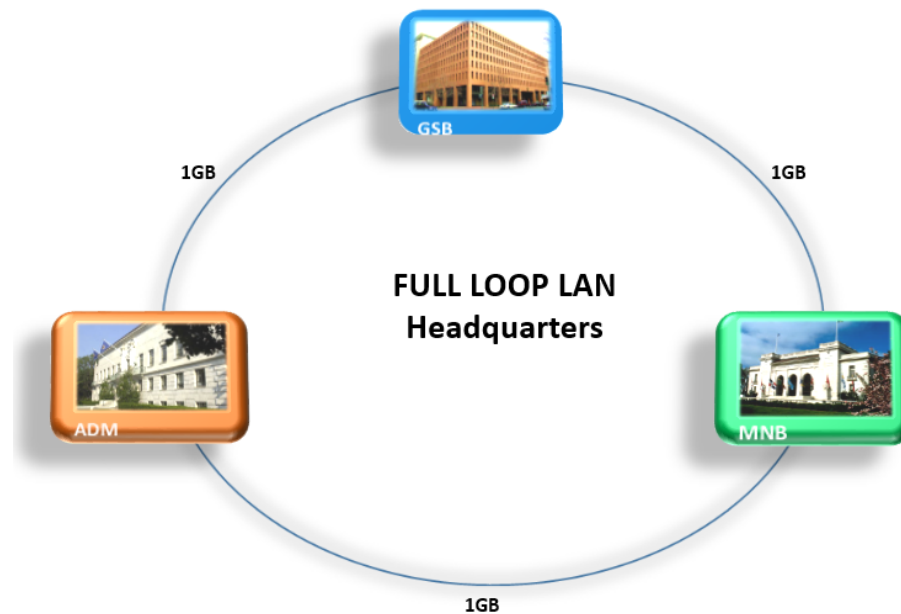

*Figure 1 LAN connection between GS/OAS buildings*

The modernization of GS/OAS information technology and communication systems, networks and platforms is imperative to keep and protect critical information and application that are vital to GS/OAS daily operation. The purpose of this RFP is to upgrade existing IT infrastructure in the following areas:

- Data Center and network,
- Servers, and
- Storage.

Each area is described in further detail below.

## 2. Description exiting equipment to be replaced.

### 2.1. Data Center and network

- **General Building (GSB)**

Currently there are two Nexus 7010s where one of them belongs to GS/OAS. Each floor has a stack of 3750X where two fiber paths go to the 5<sup>th</sup> Floor where the Nexus 7010s are located. All configurations should provide a robust and solid solution. This includes but not limited to Hot Standby Router Protocol (HSRP), Virtual portchannel (vPC), Quality of service (QoS), Power over Ethernet (PoE), routing capabilities, redundant power.

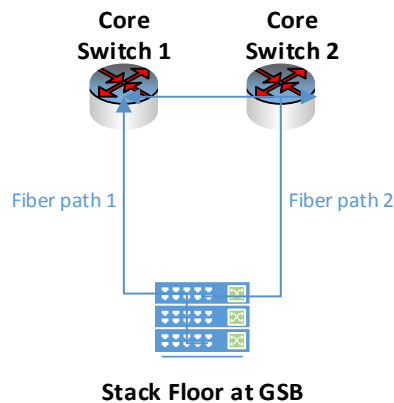

Information in detail of each Nexus 7010 as follow:

#### **GS/OAS' Nexus 7010**

- (3) 10/100/1000 Mbps Ethernet XL Module N7K-M148GT-11Lv modules
- (2) Supervisor Module-1X N7K-SUP1
- (1) 10 Gbps Ethernet XL Module N7K-M132XP-12L
- (1) 1000 Mbps Optical Ethernet XL Module N7K-M148GS-11L
- (3) N7K-AC-6.0KW

#### **Second Nexus 7010**

- (1) 1000 Mbps Optical Ethernet XL Module N7K-M148GS-11L
- (2) Supervisor Module-1X N7K-SUP1
- (3) 10 Gbps Ethernet XL Module N7K-M132XP-12L
- (3) N7K-AC-6.0KW

Here is the stack 3750X information for each floor:

- 8<sup>th</sup> Floor: (5) switches WS-C3750X-48P
- 7<sup>th</sup> Floor: (5) switches WS-C3750X-48P

6<sup>th</sup> Floor: (4) switches WS-C3750X-48P  
5<sup>th</sup> Floor: (5) switches WS-C3750X-48P  
4<sup>th</sup> Floor: (5) switches WS-C3750X-48P  
3<sup>rd</sup> Floor: (1) switch WS-C3750X-48P  
2<sup>nd</sup> Floor: (1) switch WS-C3750X-48P  
Lobby: (1) switch WS-C3750X-48P  
TL Floor: (2) switches WS-C3750X-48P

Total of 48 ports switches at GSB is: 29

All stacks should have one network module: GLC-SX-MMD 1000BaseSX SFP

*For reference: The number in between parenthesis represents the quantity of items.*

- **Administrative Building (ADM)**

The network connection within ADM is currently from one of the Nexus 7010 at GSB to one of the Nexus 5548. There are two Nexus 5548 at ADM building. The access layer at this location also consists of 3750X stacks and also single fiber connections.

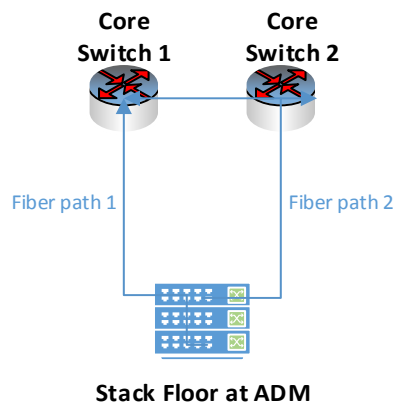

Only one location will have both fiber paths. Other locations such as ADM 3<sup>rd</sup> floor, Museum, Simon Bolivar room, and Casita building are coming in single fiber path to one core switch.

**Both Nexus 5548 are identical. Each one has the following components:**

- (1) N5K-C5548UP-SUP
- (1) N55-D160L3-V2
- (2) N55-PAC-750W

The information from each access layer at this location is as follows:

Stack ADM: (5) switches WS-C3750X-48P  
ADM 3<sup>rd</sup> Floor: (1) switches WS-C3750X-48P  
Museum: (1) switches WS-C3750X-48P  
Casita Building: (1) switches WS-C3750X-48P

Simon Bolivar Room: (3) switches WS-C3750X-48P

- **Main Building (MNB)**

For the MNB a C4506 has 3 modules with PoE and one 3750X connected to that chassis.

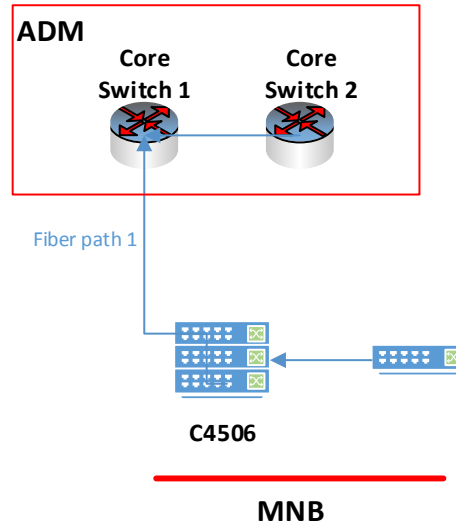

### Cisco Catalyst WS-C4506

(3) 10/100BaseTX (RJ45)V, Cisco/IEEE WS-X4248-RJ45V

(1) Supervisor IV 1000BaseX (GBIC) WS-X4515

(2) PWR-C45-2800AC

For new gear GS/OAS requests connection of 1GB for the endpoints such a VoIP phones, Access points, workstations etc.

### Cisco WS-C3750X-48P

This is another access layer which is connected to the WS-C4506 mentioned above. The model is WS-C3750X-48P with two power supplies C3KX-PWR-1100WAC.

### Wireless infrastructure:

Currently there are 2 Wireless LAN Controller (WLC) 5508 located at GSB building and 90 Access points 37021 throughout GS/OAS buildings. HA configuration is in place.

## 2.2. Servers

### Unified Computing System (UCS Servers):



Currently the Cisco server infrastructure within ADM and GSB consist of 2 chassis 5108 and 4 fabrics 6248UP. There are 6 blades in total, 2 of them are B230M2, 2 B200M2 and 2 B200M3. All these devices need to be upgraded.

Provider	Component	Product Name	Memory	Processors	Cores	Processors Reference	Network Adapter	Location	
Cisco	Fabrics interconnect	Cisco UCS 6248 UP	16					GSB	
			16					GSB	
			16					ADM	
			16					ADM	
	Chasis	Chasis 5108							GSB
									ADM
	Blades	B230 M2	128	2	16	Xeon E72830	M81KR	GSB	
		B230 M2	128	2	16	Xeon E72830	M81KR	GSB	
		B200 M2	48	2	8	Xeon E5640	M81KR	GSB	
		B200 M3	98	2	16	Xeon E5-2680	VIC 1240	GSB	
		B200 M2	48	2	8	Xeon E5640	M81KR	ADM	
		B200 M3	98	2	16	Xeon E5-2680	VIC 1240	ADM	
	IO Modules	2208XP							GSB
		2208XP							GSB
		2208XP							ADM
		2208XP							ADM

### Voice Network:

GS/OAS currently has within headquarters:

- 3 CISCO routers 3925 all of them with redundant power supply, one of the gateways is working as a passive solution in case something happen with the GSB building gateway.
- 1100 handsets as follow:
  - 750 Cisco 6921
  - 250 Cisco 8961
  - 100 Cisco 9971
- Call Manager 10.5 (1 publisher, 3 subscribers)
- Unity connection 8.6 (1 publisher, 1 subscriber)
- IM and presence 10.5 (1 publisher, 1 subscriber)
- 1100 Licenses Unified Workspace license standard

### 2.3. Storage Area Network (SAN)

The current storage system is Netapp FAS3240 with high efficiency integrated with data protection.

The Technical Specification:

Controller Form Factor: Dual Enclosure HA: 2 controllers (active-active dual controller configurations).

Memory: 16gb

Flash Cache: 1 TB

PCIe Expansion Slots :6

Onboard I/O: 4Gb FC 4

Onboard I/O: 6Gb SAS 4

Onboard I/O: GbE 4

Storage Networking Supported: FC; FCoE; IP SAN (iSCSI); NFS; CIFS; HTTP; FTP  
 Data Storage Usable: 63TB

- Storage Efficiency Deduplication Transparently removes duplicate data at the block level, for all storage tiers.
- Thin provisioning enables on-demand storage provisioning to achieve maximum utilization across multiple applications.
- FlexVol enables virtual volumes that you can manage and move independently from physical storage.
- Multi-path I/O For data-path redundancy and superior I/O performance
- Automated deduplication.

### 3. Objective and Basic Infrastructure Requirements

The main objective of this RFP is to upgrade the current legacy IT infrastructure/software and required professional services from the three main areas described in section 2 above with up-to-date technology. **The deadline for the completion of the entire project is December 15<sup>th</sup>, 2017.** The Bidder must quote the necessary equipment to match or exceed the technical specifications corresponding to the equipment being described.

This will be consider as the basic offering that has to follow all the different financial considerations, as stated in section 7.3.2 (Content of Price Proposal) of the RFP.

Line	Description	Quantity*
<b>MNB Core Network</b>		
1	4506-E Chassis, two WS-X4648-RJ45V+E, Sup7L-E, LAN Base	1
2	Console Cable 6ft with RJ-45-to-RJ-45	1
3	CAT4500e SUP8e Universal Crypto Image	1
4	Catalyst 4500 E-Series Family Slot Cover	2
5	Lan Base to Enterprise Services paper license	1
6	Catalyst 4500 E-Series Supervisor 8L-E	1
7	Catalyst 4500 2800W AC Power Supply (Data and PoE)	1
8	U.S. Power Cord, Twist Lock, NEMA 6-20 Plug	2
9	Catalyst 4500 2800W AC Power Supply (Data and PoE)	1
10	Sup8L-E and 2x WS-4748-RJ45V+E upgrade for 6-slot bundle	1
11	Catalyst 4500E 48-Port PoE 802.3at 10/100/1000(RJ45)	1
12	Catalyst 4500E 48-Port PoE 802.3at 10/100/1000(RJ45)	1
13	Catalyst 4500E 48-Port PoE 802.3at 10/100/1000(RJ45)	1
14	SNTC-8X5XNBD 4506-E Chassis,two WS-X4648-RJ45V+E,Sup7	1
<b>GSB Core Network</b>		
15	Nexus 9504 Chassis Bundle with 1 Sup, 3 PS, 2 SC, 4 FM, 3 FT	2

16	Nexus 9508 Fabric Module slot cover	4
17	Fabric Module for Nexus 9504 chassis	8
18	Nexus 9k/3K NX-OS Maintenance Software Rel 7.0(3)I5.2	2
19	Nexus 9500 Accessory Kit	2
20	Nexus 9504 Rack Mount Kit	2
21	Fan Tray for Nexus 9504 chassis, Port-side Intake	6
22	Cabinet Jumper Power Cord, 250 VAC 16A, C20-C19 Connectors	6
23	System Controller for Nexus 9500	4
24	PID to Select Default Supervisor: N9K-SUP-A	2
25	Supervisor for Nexus 9500	2
26	N9500 License PAK Expansion	2
27	LAN Enterprise License for Nexus 9500 Platform	2
28	Nexus 1000V Essential Edition Paper Delivery License Qty 96	2
29	Supervisor for Nexus 9500	2
30	PID to Select Default Power Supply: N9K-PAC-3000W-B	6
31	Nexus 9500 3000W AC PS, Port-side Intake	6
32	Nexus 9500 linecard, 48p 1/10G SFP+ & 4p QSFP	2
33	Nexus 9500 linecard, 48p 1/10G-T & 4p QSFP	2
34	Nexus 9500 Linecard slot cover	4
35	Nexus 9500 Power Supply slot cover	2
36	SNTC-24X7X4 Nexus 9504 Chassis Bundle with 1 Sup, 3	2
<b>ADM Core Network</b>		
37	2 Nexus 93180YC-EX with 8 QSFP-40G-SR-BD	1
38	Nexus 93180YC-EX bundle PID	1
39	SNTC-24X7X4 Nexus 93180YC-EX bun	1
40	Nexus 2K/3K/9K Single Fan, port side exhaust airflow	4
41	Nexus NEBs AC 650W PSU - Port Side Exhaust	2
42	Nexus 3K/9K Fixed Accessory Kit	1
43	QSFP40G BiDi Short-reach Transceiver	4
44	Nexus 93180YC-EX bundle PID	1
45	SNTC-24X7X4 Nexus 93180YC-EX bun	1
46	Nexus 2K/3K/9K Single Fan, port side exhaust airflow	4
47	Nexus NEBs AC 650W PSU - Port Side Exhaust	2
48	Nexus 3K/9K Fixed Accessory Kit	1
49	QSFP40G BiDi Short-reach Transceiver	4
50	Nexus 9k/3K NX-OS Maintenance Software Rel 7.0(3)I5.2	1
51	Cabinet Jumper Power Cord, 250 VAC 10A, C14-C13 Connectors	2
52	N9300 License PAK Expansion	1
53	LAN Enterprise License for Nexus 9300 Platform	1
54	Nexus 9k/3K NX-OS Maintenance Software Rel 7.0(3)I5.2	1

55	Cabinet Jumper Power Cord, 250 VAC 10A, C14-C13 Connectors	2
56	N9300 License PAK Expansion	1
57	LAN Enterprise License for Nexus 9300 Platform	1
58	SNTC-24X7X4 2 Nexus 93180YC-EX w	1
59	10GBASE-SR SFP Module	30
60	1000BASE-T SFP transceiver module for Category 5 copper wire	20
<b>Campus Network</b>		
61	Catalyst 2960-XR 48 GigE PoE 740W, 2 x 10G SFP+, IP Lite	44
62	1025W AC Config 2 Power Supply	44
63	North America AC Type A Power Cable	88
64	Catalyst 2960-X FlexStack Plus Stacking Module	44
65	Cisco FlexStack 50cm stacking cable	44
66	SNTC-8X5XNBD Catalyst 2960-XR 48 GigE PoE 740W, 2 x 1	44
67	10GBASE-SR SFP Module	88
<b>Wireless Network</b>		
68	Cisco 5520 Wireless Controller w/rack mounting kit	2
69	Power Cord, 125VAC 13A NEMA 5-15 Plug, North America	4
70	Cisco 5520 Wireless Controller DTLS License	2
71	Cisco 5520 Wireless Controller SW Rel. 8.1	2
72	770W AC Hot-Plug Power Supply for 5520 Controller	2
73	1.90 GHz E5-2609 v3/85W 6C/15MB Cache/DDR4 1600MHz	2
74	Trusted Platform Module 1.2 for UCS (SPI-based)	2
75	Cisco 5520 Wireless Controller Security Bezel	2
76	32GB SD Card for UCS servers	2
77	8GB DDR4-2133-MHz RDIMM/PC4-17000/single rank/x4/1.2v	8
78	770W AC Hot-Plug Power Supply for 5520 Controller	2
79	PCIe Network Interface 20G	2
80	240GB 2.5 inch Enterprise Value 6G SATA SSD	2
81	SNTC-8X5XNBD Cisco 5520 Wireless Controller	2
82	802.11ac W2 AP w/CA; 4x4:3; Mod; Int Ant; mGig B Domain	90
83	Ceiling Grid Clip for Aironet APs - Recessed Mount (Default)	90
84	802.11n AP Low Profile Mounting Bracket (Default)	90
85	Cisco Aironet 3800 Series CAPWAP Software Image	90
86	Cisco Ent MGMT: Lic For PI 3.x And APIC EM Solution Apps	1
87	Cisco Ent MGMT: PI 3.x LF, AS & APIC-EM Lic, 1 AP	120
88	SWSS UPGRADES Cisco Ent MGMT PI 3.x LF, AS APIC-EM	120
89	Cisco Ent MGMT: PI 3.x Platform Base Lic	1
90	SWSS UPGRADES Cisco Ent MGMT PI 3.x Platform Base Lic	1
91	Top Level SKU for 5520 AP Adder Licenses	1
92	Cisco 5520 Wireless Controller 1 AP Adder License	90

93	SWSS UPGRADES Cisco 5520 Wireless Controller 1 AP Ad	90
94	SWSS UPGRADES Top Level SKU for 5520 AP Adder Licenses	1
95	900GB 6Gb SAS 10K RPM SFF HDD/hot plug/drive sled mounted	4
96	Power Cord, 200/240V 6A North America	2
97	2.30 GHz E5-2650 v3/105W 10C/25MB Cache/DDR4 2133MHz	1
98	16GB DDR4-2133-MHz RDIMM/PC4-17000/dual rank/x4/1.2v	4
99	770W AC Hot-Plug Power Supply for 1U C-Series Rack Server	2
100	Cisco 5520 Wireless Controller w/rack mounting kit	2
101	Cisco 12Gbps SAS 1GB FBWC Cache module (Raid 0/1/5/6)	1
102	Cisco 12G SAS Modular Raid Controller	1
103	32GB SD Card for UCS servers	2
104	10GBASE-SR SFP Module	8
<b>Compute UCS</b>		
105	UCS SPSelect B200M4 Adv1 w/2xE52690 v4,8x32GB,VIC1340	6
106	B200M4 Adv1w/2xE52690v4,8x32GB,VIC1340	6
107	2.60 GHz E5-2690 v4/135W 14C/35MB Cache/DDR4 2400MHz	12
108	32GB DDR4-2400-MHz RDIMM/PC4-19200/dual rank/x4/1.2v	48
109	Cisco FlexStorage 12G SAS RAID controller with Drive bays	6
110	Cisco UCS VIC 1340 modular LOM for blade servers	6
111	FlexStorage blanking panels w/o controller, w/o drive bays	12
112	Cisco M4 - v4 CPU asset tab ID label (Auto-Expand)	6
113	CPU Heat Sink for UCS B200 M4/B420 M4 (Front)	6
114	CPU Heat Sink for UCS B200 M4/B420 M4 (Rear)	6
115	SNTC 24X7X4OS, (Not sold standalone)B200M4 Adv1w/2xE52690v4,	6
116	UCS SP Select 120 GB Enterprise Value 6G SATA SSD 4 Pk	3
117	UCS SP Select 120 GB Enterprise Value 6G SATA SSD	12
118	UCS 5108 Blade Server AC2 Chassis/0 PSU/8 fans/0 FEX	2
119	SNTC-8X5XNBDOS UCS 5108 AC Chassis, updated backplane	2
120	Single phase AC power module for UCS 5108	2
121	UCS 5108 Packaging for chassis with half width blades.	2
122	Accessory kit for UCS 5108 Blade Server Chassis	2
123	Blade slot blanking panel for UCS 5108/single slot	10
124	Fan module for UCS 5108	16
125	2500W Platinum AC Hot Plug Power Supply - DV	8

126	Cabinet Jumper Power Cord, 250 VAC 16A, C20-C19 Connectors	8
127	UCS 5108 Blade Chassis FW Package 3.1	2
128	UCS 2208XP I/O Module (8 External, 32 Internal 10Gb Ports)	4
129	WS-C4507R+E Chassis, two WS-X4648-RJ45V+E, Sup7L-E, LAN Base	2
130	SNTC-8X5XNBD WS-C4507R+E Chassis,2 WS-X4648-RJ45V+E	2
131	Cisco UCS 2208XP I/O Module	4
132	Cisco UCS 6248UP 1RU Fabric Int/No	4
133	Cisco UCS 6248UP 100-240VAC	8
<b>Compute Storage</b>		
134	SW-2,Base,CL,Node	1
135	Cabinet Component Power Cable, R6	1
136	ONTAP,Per-0.1TB,FlashBundle,HC-U-Perf,1P,-P	300
137	Cable,12Gb,Mini SAS HD to HD,1m	2
138	Rail Kit,4-Post,Rnd/Sq-Hole,Adj,24-32	4
139	SupportEdge Premium 4hr Onsite, w/o Install	1
140	AFF A200 HA System,Flash Bundle	2
141	SW,Trusted Platform Module Enabled,A200,-C	2
142	AFF A200,24X3.8TB SSD,-C	1
143	SFP+ Optical 10Gb Shortwave,-C	8
144	Documents,AFF-A200,-C	1
145	Data at Rest Encryption Capable Operating Sys	1
146	Optimized SSD Personality	1
147	ONTAP,Per-0.1TB,FlashBundle,HC-U-Perf,1P,-C	600
148	Cable,LC-LC,OM4,5m	8
149	Cable,Direct Attach CU SFP+ 10G,0.5M	2
150	Rail Kit,4-Post,Rnd/Sq-Hole,Adj,24-32	1
151	Cabinet Component Power Cable, R6	2
152	FlexPod Support	1
153	SupportEdge Premium 4hr Onsite, w/o Install	1
<b>Voice Collaboration</b>		
154	Unified Border Element Enterprise 100 sessions E RTU	6
155	Cisco ISR 4431 Bundle with UC & Sec Lic, PVDM4-64, CUBE-25	2
156	Blank faceplate for NIM slot on Cisco ISR 4400	4
157	IP Base License for Cisco ISR 4400 Series	2
158	PVDM4 64-channel to 256-channel factory upgrade	2
159	AC Power Supply for Cisco ISR 4430	2
160	AC Power Supply (Secondary PS) for Cisco ISR 443	2
161	AC Power Cord (North America), C13, NEMA 5-15P, 2.1m	4

162	Unified Border Element Enterprise License - 25 sessions	2
163	Security License for Cisco ISR 4400 Series	2
164	4G DRAM (2G+2G) for Cisco ISR 4400	2
165	Unified Communication License for Cisco ISR 4400 Series	2
166	2G DRAM (1 DIMM) for Cisco ISR 4400 Data Plane	2
167	8G eUSB Flash Memory for Cisco ISR 4430	2
168	2-port Network Interface Module - FXO (Universal)	2
169	Cisco ISR 4400 Series IOS XE Universal	2
170	SNTC-24X7X4 Cisco ISR 4431 UC Se	2
171	Cisco Unified IP Color Key Expansion Mod	25
172	Cisco UC Phone 6921, Charcoal	885
173	Cisco UC 8961 Standard Handset	90
174	IP Phone pwr transformer for the 89/9900	25
175	Emergency Responder Electronic or Physical Software Delivery	1
176	EMRGNCY RSPNDR USR LIC 1 PHN FOR NEW 11X SYSTEM	975
177	SWSS UPGRADES EMRGNCY RSPNDR USR LIC 1 PHN FOR NEW 11X	975
178	EMRGNCY RSPNDR 11.0 SW NEW	1
179	EMRGNCY RSPNDR 11.X PAK	1
180	SWSS UPGRADES EMRGNCY RSPNDR	1
181	Cisco Unified Communications Manager 11.5	1
182	Services Mapping SKU, 1K-10K UWL STD users	1100
183	UC Manager Enhanced 11.x License	18
184	Analog, non-app device add-on for UWL	112
185	CCX 8.5 Promo Bundle available only with NEW CUCM or BE6000	1

\*The quantity information is subject to change based on Technical Proposals from each Bidder. As part of the basic infrastructure offering the Bidders must quote the value for all associated professional services needed, including a Project Manager, in order to deploy and configure each area, as stated section 7.3.1 (Documents related to Bidder's Personnel) of the RFP.

#### **4. Optional Infrastructure and Services**

Additionally, to the Basic Infrastructure requirements stated in section 3 above, every Bidder must offer the following items identified as Optional Infrastructure and Services:

##### **Compute**

- Upgrade Vsphere 5.5 enterprise licensing to VSphere 6 with operation management enterprise
- Upgrade VCenter 5.5 to Vcenter 6.0 Standard for Vsphere 6

## **Storage**

- Replace Netapp FAS2240 for FAS2650 HA System With 50 TB Usable
- Increase GSB Storage by 40 TB more than proposed solution.

## **VOIP**

- Infotel Call Accounting (ISI) for Call detail record (CDR) management and billing.

## **Security**

- Replace current GSB ASA 5540 for Cisco Firepower 4110.
- Replace current ADM ASA 5520 for Cisco Firepower 2140.
- Sourcefire AMP for FirePOWER for GSB and ADM Firewalls.
- Cisco FireSIGHT management Center for monitoring, configuration and reporting.
- 3 Physical servers, with RAID 5 capabilities, 500Gb Storage, 12 CPU Cores, 128Gb RAM
- Cisco AMP for 1200 endpoints.
- Bluecoat SG-400-30 appliance with SSL interception capabilities.

## **Network**

- Upgrade the VPN licenses to Anyconnect Plus (500 licenses)
- Upgrade the Catalyst 3550 to newer Internet Edge ISR 4431
- Upgrade DMZ infrastructure from a single Catalyst 2960 to a dual Catalyst 3850
- Deploy a management solution for wireless and wired networks with Cisco Prime Infrastructure
- Deploy a secure network access with Cisco Identify Services Engine.

## **Backup**

- Replace storage Netapp FAS2554 for FAS2650 HA System With capacity of 100 TB Usable
- Upgrade Veeam 9.5 Backup Software licenses.
- Upgrade Backup Storage Netapp FAS2554 with capacity of 50 TB for secondary data center.
- Increase cloud backup capacity by 25 TB and deploy AltaVault Ava-400.

The GS/OAS reserves the right to include any optional equipment described in section 4 into the Basic Infrastructure requirements.

All Bidders are required to submit a Proposal that considers both Basic Infrastructure and Optional Infrastructure and Services, as indicated in section 7.3.2 (Content of the Price Proposal) of the RFP.



## APPENDIX 2

### CONTRACTUAL TERMS AND CONDITIONS

1. Lessor is neither an employee nor a staff member of GS/OAS and is not entitled to any of the rights, benefits, and emoluments of GS/OAS staff members.
2. Lessor undertakes to perform Lessor's functions under this Contract and to regulate Lessor's conduct in conformity with the nature, purposes, and interests of the GS/OAS. Lessor shall complete the Work in accordance with the highest professional standards and shall conform to all governmental pertinent laws and regulations.
3. Lessor accepts full legal responsibility for the Work, including all liability for any damages or claims arising from it, and agrees to hold GS/OAS and its staff members harmless from all such damages or claims. Lessor shall provide certificates of insurance coverage as GS/OAS may require for proof of ability to cover such liability.

- 3.1 Mistakes: Lessor shall be liable for improper or incorrect use of the data collected or information disclosed to Lessor by GS/OAS in connection with its Proposal, and/or in connection with any subsequent contract negotiations between GS/OAS and the Lessor.

The data and related information are legal documents and are intended to be used as such.

Lessor takes full responsibility for any errors or mistakes with respect to its Proposal. Lessor has used its best efforts to ensure the accuracy, reliability and completeness of its proposal, and agrees that any cost of any modification of proposal or contract terms based on Lessor's error in the information it has provided with its proposal shall be borne solely by Lessor.

- 3.2 Indemnification to Third Parties for Lessor's Negligent or Wrongful Acts: Lessor shall fully indemnify and hold harmless the Organization of American States, GS/OAS, and its officials, employees, agents, affiliates, successors and assigns from and against: (i) all claims, damages, actions, liabilities, losses, fines and penalties, and expenses, including but not limited to attorneys' fees, arising out of or resulting from Lessor's negligence or deliberate wrongful acts in relation to the Contract, and (ii) worker compensation claims and actions presented by Lessor's employees and agents.

GS/OAS shall notify Lessor as soon as reasonably practicable after any claim covered by this Section is made against it or, with respect to any such claim made against any other person or identity entitled to indemnification under the Contract, within a reasonably practicable time after having been notified of that claim.

Lessor is liable to GS/OAS and shall indemnify GS/OAS for losses to GS/OAS' property sustained through any acts committed by Lessor's employees, agents, and/or subcontractor acting alone or in collusion. Such acts include, but are not limited to, actual destruction, disappearance, or wrongful abstraction of property, money, or securities.

The provisions of this Section shall not be so construed as to affect any waiver of subrogation rights on the part of any insurance company, as provided in any policy of insurance covering GS/OAS.

- 3.3 Insurance: For the duration of the Contract, Lessor shall purchase and maintain in a

company or companies, to which the GS/OAS has no reasonable objection, such insurance as will protect the Lessor, the GS/OAS, and the OAS, from claims set forth below, which may arise from operations under this Contract by Lessor or by a subcontractor of Lessor or by anyone directly or indirectly employed by any of them, or by anyone for whose acts they may be liable. Lessor is required to carry insurance with limits equal to or greater than those set forth in the table below:

Commercial General Liability	\$1,000,000 Personal/Bodily Injury. \$1,000,000 Each Occurrence. \$2,000,000 Products/Completed Operations Aggregate. \$2,000,000 General Aggregate, per premises aggregate.
Business Automobile	\$1,000,000 Each Accident.
Worker's Compensation	Statutory Limits or \$500,000, whichever is greater, based on the benefits levels of the deemed state of hire.
Employer's Liability	\$1,000,000 Bodily Injury by Accident Per Employee. \$1,000,000 Bodily Injury by Disease Per Employee. \$1,000,000 Bodily Injury by Disease Policy Limit.
Umbrella/Excess Liability	\$5,000,000 Each Occurrence. \$5,000,000 Aggregate, per Project.

Lessor shall name the GS/OAS as an additional insured under such policies, and shall provide the GS/OAS with a certificate evidencing the above insurance coverage. Should any of the above-described insurance policies be cancelled before the expiration date indicated in the respective certificate provided to the GS/OAS, the Lessor shall give to the GS/OAS written notice and provide a new certificate of insurance that evidences the insurance policy required.

Lessor shall require all subcontractors to have insurance having the same or similar coverage as that specified above. Lessor is required to provide GS/OAS with proof of those insurance policies on request.

Lessor's liability insurance shall include contractual liability insurance sufficient to cover Lessor's obligations under this Paragraph.

- 3.4 Subcontractors: The Lessor may enter into a contract or contractual action for the purpose of obtaining supplies, materials, equipment, or services under the Contract.

GS/OAS' written consent is required for the Lessor to enter into a particular subcontract.

Lessor is fully responsible for Contract performance, regardless of any team arrangement between the Lessor and its Subcontractors.

4. Lessor does not legally represent GS/OAS, shall not hold himself out as having such powers of representation, and shall not sign commitments binding GS/OAS.
5. Lessor shall not have any title, copyright, patent, or other proprietary rights in any Work furnished under this Contract. All such rights shall lie with GS/OAS. At the request of GS/OAS, the Lessor shall assist in securing the intellectual property rights produced under this Contract and in transferring them to GS/OAS.
6. All information (including files, documents, and electronic data, regardless of the media it is in) belonging to GS/OAS and used by Lessor in the performance of this Contract shall remain the property of GS/OAS. Unless otherwise provided in the Terms of Reference (Appendix 1), Lessor shall not retain such information, and copies thereof beyond the termination date of this Contract, and Lessor shall not use such information for any purpose other than for completion of the Work.
7. Lessor certifies that he has read and agrees to comply fully with the following documents: Administrative Memorandum No. 120 "Information Security Policy", <http://www.oas.org/legal/english/admmem/admmem120.pdf>, Executive Order No. 15-02 "Policy and Conflict Resolution System for Prevention and Elimination of All Forms of Workplace Harassment" <http://www.oas.org/legal/english/gensec/EXOR1502.htm>, and Executive Order No. 12-03 "Code of Ethics of the General Secretariat" <http://www.oas.org/legal/spanish/gensec/EXOR1203.htm>.
8. The Gross Compensation paid Lessor constitutes full consideration for the Work. It covers all fees, expenses, and costs incurred by Lessor in providing the Work, as well as Lessor's direct compensation for same.
9. Because Lessor is an independent Lessor, GS/OAS is not responsible for providing social security, workmen's compensation, health, accident and life insurance, vacation leave, sick leave, or any other such emoluments for Lessor and his employees under this Contract. Lessor is solely responsible for providing those benefits, and the Parties have agreed upon the Gross Compensation hereunder to enable Lessor to satisfy that responsibility. At the request of GS/OAS, the Lessor will provide satisfactory evidence of workman's compensation and other insurance coverage that may be required for all its employees or such Lessors.
10. Lessor warrants that his performance of the Work will not violate applicable immigration laws, and Lessor shall not employ any person for the performance of this Contract where such employment would violate those laws.
11. Unless otherwise specified in this Contract, Lessor shall have the sole responsibility for making Lessor's travel, visa, and/or customs arrangements related to and/or required for the performance of this Contract, and GS/OAS shall have no responsibility for making or securing such arrangements.
12. This Contract shall be null and void in the event the Lessor is unable to obtain a valid visa and other permits or licenses necessary to complete the Work in the country where the Contract is to be performed.
13. Unless otherwise specified in this Contract, Lessor shall neither seek nor accept

instructions regarding the Work from any government or from any authority external to the GS/OAS. During the period of this Contract, Lessor may not engage in any activity that is incompatible with the discharge of Lessor's obligations under this Contract. Lessor must exercise the utmost discretion in all matters of official business for GS/OAS. Lessor may not communicate at any time to any other person, government, or authority external to GS/OAS any information known to him by reason of his association with GS/OAS which has not been made public, except in the course of the performance of Lessor's obligations under this Contract or by written authorization of the Secretary General or his designate; nor shall Lessor at any time use such information to private advantage. These obligations do not lapse upon Contract termination. Failure to comply with these obligations is cause for termination of this Contract.

14. Unless specifically provided for in this Contract<sup>1</sup> in accordance with CPR Rule 5.13.1, the Lessor may not directly supervise a GS/OAS staff member or direct a project or mission that requires the Lessor to supervise GS/OAS staff members.
15. Lessor shall not openly participate in campaign activities for or otherwise openly support and or promote any candidate for elected positions in the OAS; nor shall Lessor use the facilities of the GS/OAS and/or its staff provided to him under this Contract to support and promote the candidacy of any candidate for an elected position in the OAS.
16. GS/OAS may terminate this Contract for cause with five days' notice in writing to the Lessor. Cause includes, but is not limited to: failure to complete the Work in accordance with professional standards or to otherwise deliver conforming goods and services; failure to meet deadlines; conduct which damages or could damage relations between the OAS and a member state; fraudulent misrepresentation; criminal indictment; sexual harassment; workplace harassment; bankruptcy; conduct incommensurate with the requirements for participation in OAS activities; and breach of any of the provisions of this Contract.
17. Either party may terminate this Contract for unforeseen circumstances by giving at least thirty days' notice in writing to the other. Unforeseen circumstances include, but are not limited to, modifications to the Program-Budget of the OAS; lack of approved funds in the OAS Program-Budget for the corresponding program or project; failure of a donor to provide fully the specific funds which were to finance this Contract; an act of God; and the Secretary General's or a member state's desire to discontinue the Work.
18. In the event this Contract is terminated with or without cause, Lessor shall submit to GS/OAS all of the Work completed and shall receive payment for only that portion of the Work completed to the satisfaction of GS/OAS up until the date of termination.
19. Lessor certifies that:
  - a) Neither the Lessor nor any of its senior officers and employees, on the date of the signing of this Contract, is a relative of any GS/OAS staff member above the P-3 level or of a representative or delegate to the OAS from an OAS Member State. The term "relative" includes spouse, son or daughter, stepson or stepdaughter, father or mother, stepfather or stepmother, brother or sister, half-brother or half-sister, stepbrother or stepsister, father or mother-in-law, son or daughter-in-law, brother or sister-in-law.

---

<sup>1</sup> Any such provision must comply with the requirements of CPR Rule 5.13.1 in Executive Order No. 05-04, Corr. No. 1 at <http://www.oas.org/legal/english/gensec/EXOR0504CORR1.doc>.

- b) He is not incompetent to enter into this Contract, is not on trial in a criminal court of any of the member states, and has never been convicted of a felony or of any crime involving dishonesty, fraud or theft in any member state.
  - c) Completion of the Work shall not interfere with the completion of work for which he is responsible under any other contract with GS/OAS.
20. Lessor shall not employ a staff member of GS/OAS or a relative of a staff member as defined in Paragraph 19 (a) above to perform the Work, nor shall Lessor permit any staff member of GS/OAS or any relative of the staff member, as defined in that Paragraph, to receive any personal financial benefit deriving from this Contract or the Lessor's contractual relationship with GS/OAS.
  21. Lessor shall not assign this Contract or any element thereof, without the prior written consent of GS/OAS.
  22. Upon written notice by either Party to the other, any dispute between the Parties arising out of this Contract may be submitted to the American Arbitration Association, for final and binding arbitration in accordance with the selected entity's rules. The law applicable to the Arbitration proceedings shall be the law of the District of Columbia, USA, and the language of the arbitration shall be English.
  23. Nothing in this Contract constitutes an express or implied waiver by GS/OAS of its privileges and immunities under the laws of the United States of America or international law.
  24. This Contract shall enter into effect on the date on which it is signed by both Parties. Provided, further, that this Contract shall have no legal effect until it has been signed by both Lessor and a duly authorized representative of the GS/OAS.
  25. The law applicable to this Contract is the law of the District of Columbia, USA.
  26. This Contract, including Appendixes 1-3, constitutes the entire agreement between the Parties, and any representation, inducement, or other statements not expressly contained herein shall not be binding on the Parties and shall have no legal effect.
  27. The masculine terms employed in this Contract should be understood to apply to males, females and legal persons; singular pronouns should be understood to apply to the plural, when appropriate.

**APPENDIX 3**

**FORMAT 1**

**CONFLICT OF INTEREST STATEMENT**

General Secretariat of the Organization of American States  
1889 F Street, N.W., 4<sup>th</sup> Floor,  
Washington, D.C. 20006  
USA

Attention: Department of Procurement Services

**Subject: BID 05/17 – CAPITAL LEASE FINANCING FOR  
INFORMATION TECHNOLOGY EQUIPMENT, SOFTWARE AND  
ASSOCIATED PROFESSIONAL SERVICES FOR THE GENERAL SECRETARIAT  
OF THE ORGANIZATION OF AMERICAN STATES**

I \_\_\_\_\_, representative of \_\_\_\_\_ (*Bidder's name*), declare that \_\_\_\_\_ (*Bidder's name*) does not fall under the following prohibitions:

- a) A staff member of GS/OAS;
- b) Any person who has held the post of Secretary General or Assistant Secretary General, or a position of trust unless the contract is approved by the Secretary General or the Chief of Staff of the Secretary General;
- c) Any delegate, diplomatic representative, or other government employee of an OAS Member State;
- d) Any relative of a GS/OAS staff member above the P-3 level or a relative of any other GS/OAS staff member who has authority to issue the subject contract;
- e) Any relative of a representative or delegate of a Member State to the OAS;
- f) Any person who has entered into a performance contract terminated by GS/OAS for cause under Chapter 8 of the Performance Contract Rules;

- g) Any person employed by an institution that is receiving funds from the GS/OAS as part of a GS/OAS Project, except in those cases where the employee is on leave without pay from that institution;
- h) Any person who is legally incompetent; any person who is on trial in a criminal court of any OAS Member State; or any person convicted of a serious criminal offense in one of the Member States;
- i) Any person who has defaulted on and/or failed to perform satisfactorily an existing or previous performance contract or procurement contract with GS/OAS;
- j) Any person who does not have a valid visa to work in the country where the performance contract is to be performed and who cannot obtain one prior to the contract initiation date;
- k) Any elected official of an OAS Organ, unless the performance contract is not for or in relation to the organ on which the official serves.

Sincerely,

---

**APPENDIX 3**

**FORMAT 2**

**COMERCIAL REFERENCES**

<b>Nº</b>	<b>Name of the Company</b>	<b>Telephone, Address and e-mail address</b>	<b>POC</b>	<b>Description of the Work</b>	<b>Duration of the Project (mm/yyyy – mm/yyyy)</b>
1					
2					
3					
4					
5					